

" وفي أنفسكم أفلا تبصرون "

* 21*

:

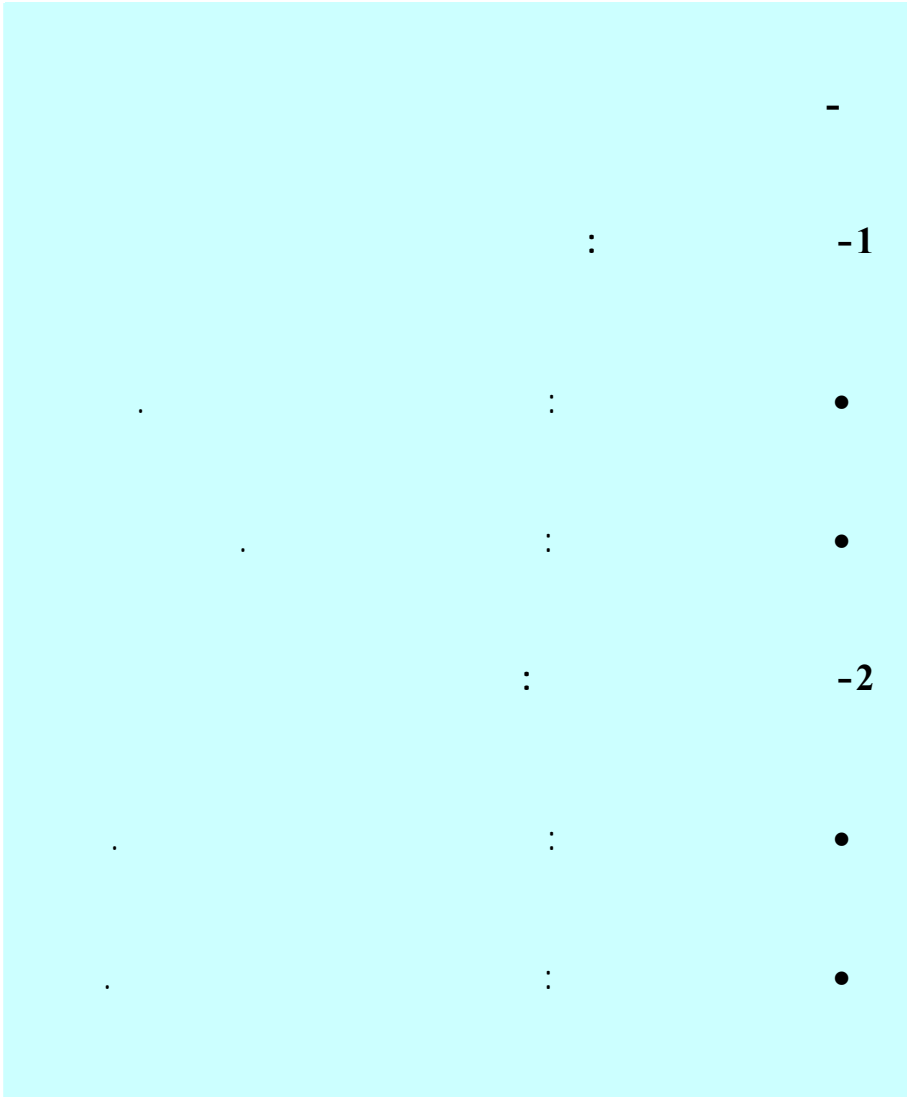



:

•

•

•

()

•

:

:

:



:

. /

: (

(1

(2

(3

(4

(5

(6

(7

(8

:

: (

*

*

:

"

"

:

"

"

-1

.()

()

()

- -

/

:

:

:

-2

-3

" : WOD WORTH تطور علم النفس

:

-4

:

-5

:

:

•

•

: Objective Method

(

:

•

() : **Subjective Method** ()

:

Analogical Method (

(

(

:

-6

:

: -1

(1927-1867)

:

()

()

(→)

:

: -2

:

)

.(

: .3

:

:

: .4

(1958 - 1878)

:

()

" "

: -5

:

:

-

-

-

()

-

:

	:17 :19	Associationalism (19_17)
() ()		Functionalism (20_19)
		Behaviourism (10)
		Gestalt (20)
		Psychoanalyze

:

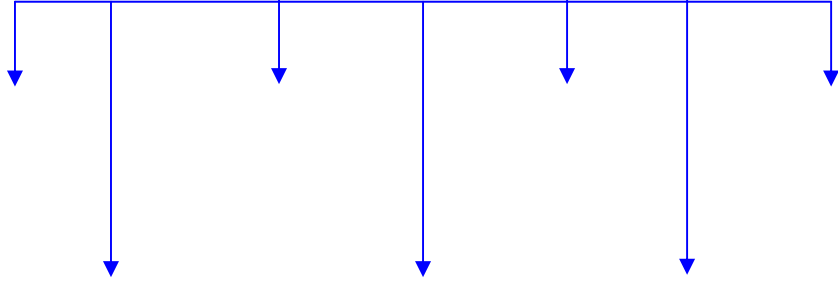

:

(

:

.1

:

: .2

)
() (

: .3

:

-7

-

-

(1

.

(2

()

(3

(4

(5

.

(6

(8

-

-

(1

.

(2

:

(3

(4

(5

(6

:

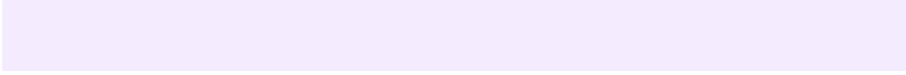

: (

-1

-2

-3

-4

19 -5

-6

21 -7

-8

24 -9

:

-10

-11

-12

-13



()

" *Motive*"

" *Motivation*"

Movere

.(1984

:

: -3

: :

•

•

:

.()

.1

.2

.3

:

-2

:

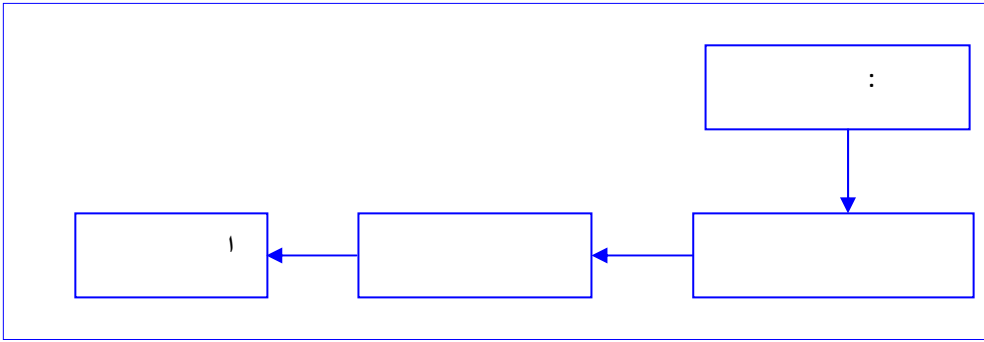
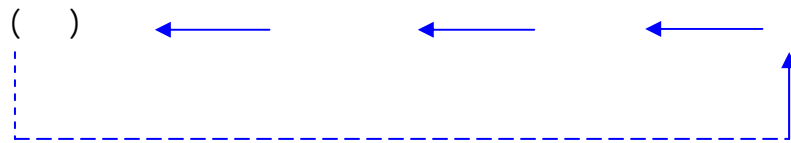

-3

:

:

-
-

:

-
-
-
-
-

-4

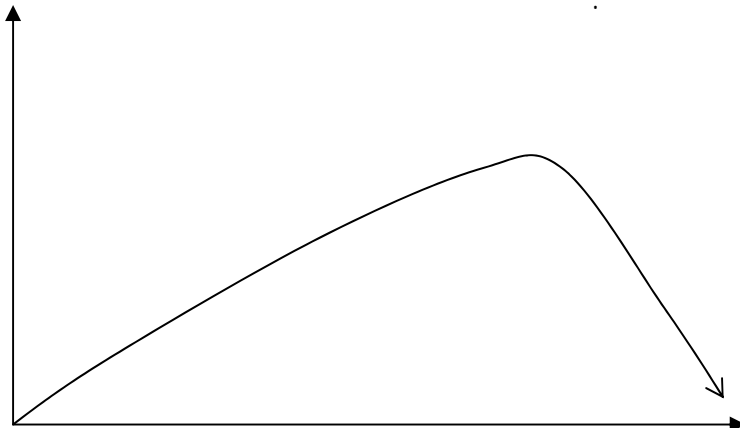

:

-5

:()

:

•

:

:

*

:

(

-

:

(

:

•

:

A. Maslow

Physiological needs	.1
Safety needs	.2
Belongingness needs	.3
Esteem needs	.4
Self_actualization needs	.5
Knowledge needs	.6

:

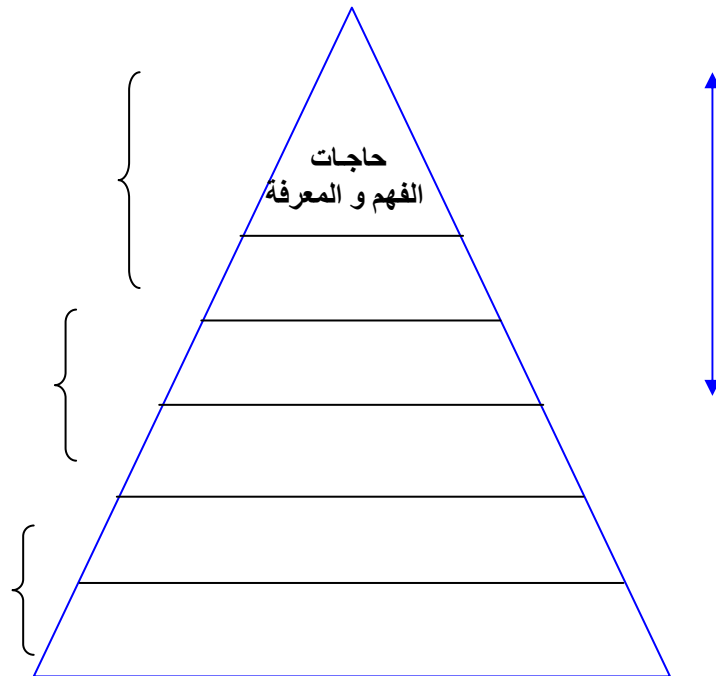

:

,1954)

.(Maslow

-7

:

: **Need** .1

: **Drive** .2

(1976)

: **Incentive** .3

" W.E. Vinacke"

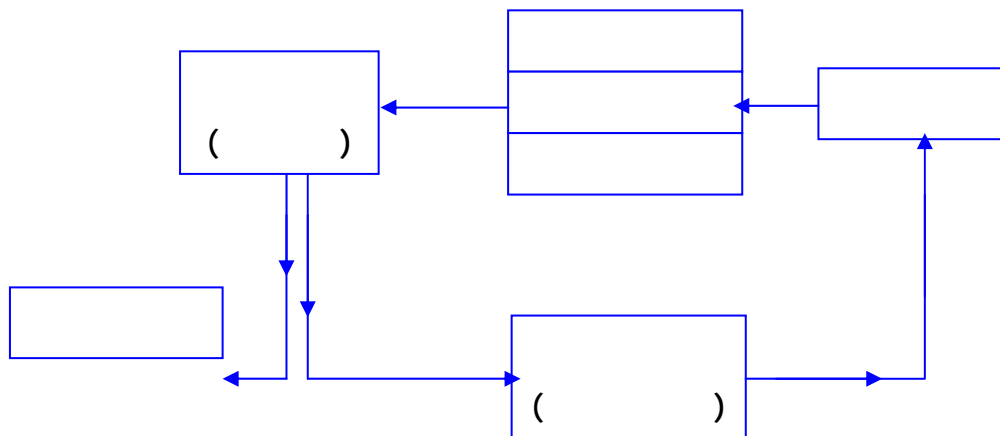

:

"

"

-9

"

"

,

:

:

.1

,

:

•

•

•

•

:

: .4

•

•

•

•

: .5

•

•

•

•

:

-10

.1

.2

.3

.4

.5

." Feed Back "

.6

.7

-11

.1

.2

.3

.4

.5

.6

.7

.8

.9

:

-12

(1

:

.

.

.

:

-

-

-

-

-

.

-

.

-

.

.

(2

(5 - 3

:

(6

.()

(7

.() .

(8

:

:

-13

1994				(1)
.		/	18	(2)
.		/		(3)
.		/		(4)
.2000	-	.	/	(5)

:



:

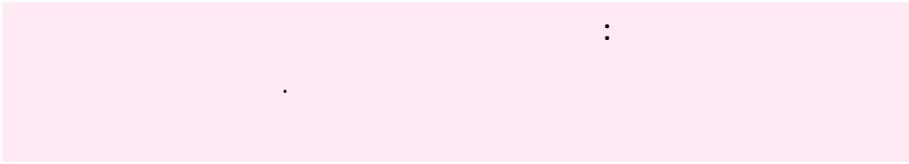

(

.1

.2

.3

•

•

•

:

:

: (*Lester Smith*)

"

...

:

"

"

.

-2

:

:

◆

◆

:

:

.() "

"

()

...

:

"

"

()

: -1

: -2

:

: -3

...

. -4

... - - -5

:

."

"

:

: -1

: -2

: -3

-3

:

(

:

: (

Education

Enseignement

" *Renon* " " "

": " *Gusdore* " "

:

.

:

(

..

" : *Foulquié*

":

."

:



	:	(
()		.1	
()		.2	
..... ()	/	.3	
Le Constructivisme – Jean Piaget –		.4	
-	:	.5	
		.6	
		.7	
		.8	
		.9	

:

(

() -1

" "

:

-1

-2

-3

-4

-5

-6

-7

-8

:

() -2

"

"

Jean

"

"

(1778-1712) *Jacques Rousseau*

: "EMILE"

:

-1

"

"

:

-2

:

:

◆

:

◆

:

◆

:

-3 التأكيد على السلبية وعلى الأخص قبل سن 12 :

"

'

,

,

.

:

-4

:

,

,

.

-3 / () :

, 1952-1859 *John Dewey*

:

:

:

-1

-

-

-

,

.

:

-2

,

) () (Situation) () :
 -3
 -4
 -5
 -6

Le Constructivisme – Jean Piaget – -4

1930 *Piaget* :
 :
 :
 : - -

:

: Piaget

: -1

Piaget

...

: -2

(7-2)

()

: (11-7) -3

Piaget

:

:()

-4

11

.

- :

-5

:

.

:

,

:

(1

"

.(72-71)

' ' "

,

"

,

:

:

.(33-30) ' ' "

:

"

"

.(164) ' ' "

:

(3

"

(13) ' ' "

(4

:

"

(97) ' ' "

"

" ...

(32) ' ' "

:

(2

"

(3-1) ' ' "

:

" "

(4) ' ' :

-2 . -1

-4 . -3

-5

-6

: (468 - 370) : -1

"

" :

" :

...

...

" :

" :

:

"

":

"

":

"

:(505 - 450) : -2

"

"

"

"

... "

" ...

... " :

"

:

:

: (808 - 734)

-3

" "

:

:

" :

" ...

" :

"

...

" :

'

..

"

,

" (1

(2

(3

" : (4

" (5

(6

(7

" : " " (8

(9

" : " " (10

:

-8

(1

(2

(5 - 4

:

:

(6

- :

-

-

:

-

-

:

-
(7

" "

(8

(9

(10

. 2002 : : •
 : •
 •
 : , -
 . 1998 , -

•
 :
 .2001

•
 : , -
 : , :
 •
 :
 :

:

.1993

•

.1990

_

.1974_1973 ,

•

•

,

:

.

,

,

,

:

1977 .